

# FPM-3190

## Industrial 19" Flat Panel Monitor with VGA/DVI/Video/S-Video Port



### Features

- 19" SXGA TFT LCD with resolution up to 1280 X 1024
- Stainless steel chassis with NEMA4/IP65-compliant stainless front panel (aluminum optional)
- Multi-scan function supports SXGA, XGA, SVGA, VGA, text mode
- High luminance up to 250 cd/m<sup>2</sup>
- Auto-recognition of input signal
- Supports panel, wall, rack mount or VESA arm
- Multi-signal input supports VGA, DVI-D, Video and S-Video

### Introduction

The FPM-3190 is a 19-inch color TFT LCD flat panel monitor specifically designed for industrial applications. With a viewing size as large as 19", it presents an ample display area as well as vivid and sharp images for your HMI. The FPM-3190 features multi-signal input support for VGA, DVI-D, Video and S-Video. Users can thus upgrade the display without making changes to the existing system. Its on screen display function also allows users to adjust the images on screen with ease. The whole chassis is stainless steel and the front panel is made of stainless with NEMA4/IP65 compliance.

### Specifications

- **Front Panel** Stainless, NEMA4/IP65 compliant. (aluminum optional)
- **Mounting** Panel, wall, rack mount or VESA arm
- **Dimensions (WxHxD)** 482 x 399 x 66 mm (19" x 15.7" x 2.6")
- **Gross Weight** 10 kg (22 lbs)
- **I/O Port** VGA, DVI-D, Video, S-Video, DC power input, power switch, and RS-232 port (Touchscreen version only)
- **Control** OSD (On Screen Display) Control Pads on the front panel
- **Power** External 48 W power adapter, with AC 100 V ~ 230 V input and DC +12 V @ 4 A output
- **Operating Temperature** 0 ~ 50° C (32 ~ 122° F)
- **Storage Temp** -20 ~ 60° C (-4 ~ 140° F)
- **Storage Humidity** 5 ~ 95% non-condensing
- **Vibration (operating)** 5 ~ 17 Hz, double-amplitude displacement 17 ~ 500 Hz, 1.0 G peak to peak
- **BSMI, CE, CCC and FCC compliant**

#### LCD Display

- **Display Type** SXGA TFT LCD
- **Display Size** 19"
- **Max. Colors** Full color (16.7 million)
- **Max. Resolution** 1280 x 1024
- **Viewing Angle** 170° (H), 170° (V)
- **Luminance** 250 cd/m<sup>2</sup> 4 CCFL
- **Storage Temperature** -20 ~ 60° C (-4 ~ 140° F)
- **Operating Temperature** 0 ~ 50° C (32 ~ 122° F)
- **Backlight Lifetime** 50,000 hrs
- **Contrast Ratio** 600: 1 (typ.)

#### Touchscreen (Optional)

- **Type** Capacitive sensor
- **Resolution** 1024 x 1024
- **Light Transmission** 88 %
- **Controller** RS-232 interface
- **Power Consumption** +5 V @ 200 mA
- **OS Support** Windows 2000/XP
- **Lifespan** 225 million touches

### Ordering Information

- **FPM-3190TV** Industrial 19" TFT LCD display with 19" Rack-Mount Bezel, VGA/DVI/Video interface and AC 100~230 V input 48W power adapter
- **FPM-3190TV-TC** FPM-3190TV with capacitive touchscreen (RS-232 interface)
- **9689000355** RS-232/485 converter for T/S (USA)
- **9689000356** RS-232/485 converter for T/S (UK)
- **9689000357** RS-232/485 converter for T/S (FR)

#### Option

- **Aluminum front panel by request**

**Dimensions**

Unit: mm

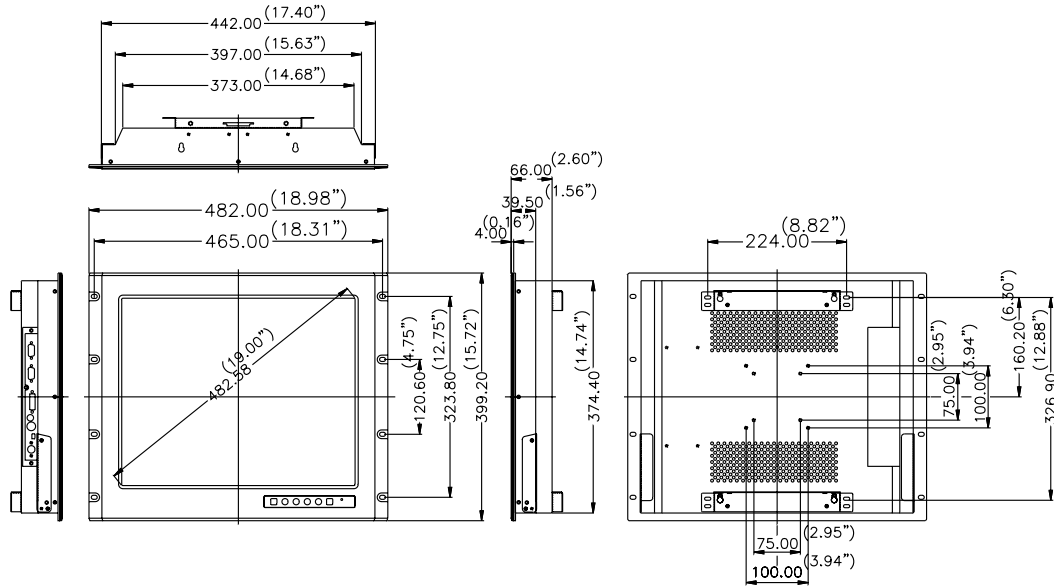

Cut-out dimension: 444 x 376 mm (17.48" x 14.84")

**Side View**



- 1 IPPC & AWS
- 2 TPC
- 3 FPM
- 4 ATM
- 5 DA&C
- 6 cPCI
- 7 ADAM-3000
- 8 eConnectivity
- 9 ICOM
- 10 Software
- 11 UNO-2000/3000
- 12 VBOX
- 13 ADAM-4000
- 14 ADAM-5000
- 15 ADAM-6000
- 16 ADAM-8000