

➤ AM5010

Processor AMC Module based on
Intel® Core™ 2 Duo

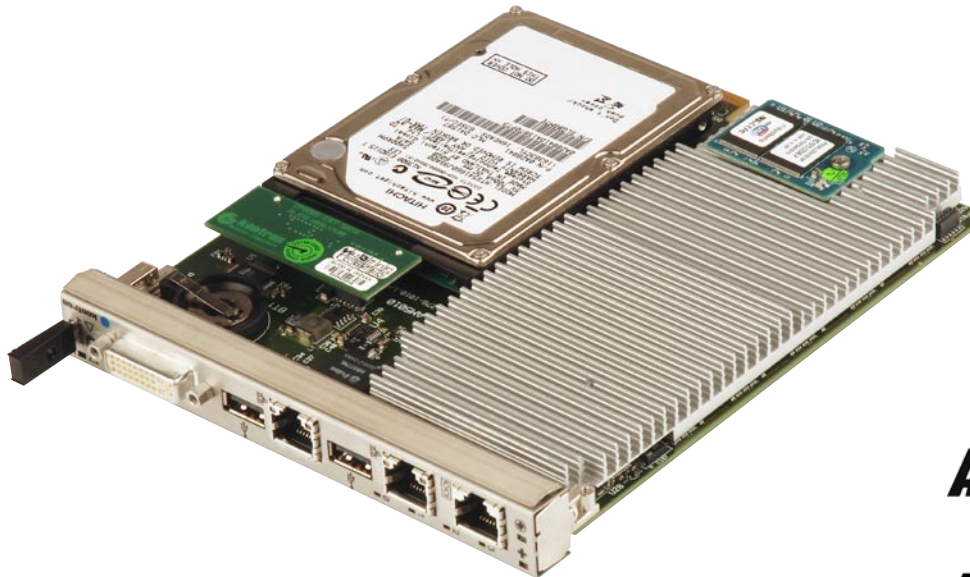

AdvancedMC™

AdvancedTCA®



➤ Ultra Performance

Intel® Core™ 2 Duo with 1.5 GHz

➤ Ultra Capacity

Up to 4 GB memory DDR2 400 MHz

Up to 8 GB NAND Flash

➤ Ultra I/O Capability

2x GbE, DVI, 2x USB, onboard SATA, onboard USB Flash
PCIe (AMC.1), 2x GbE (AMC.2), 2x SATA (AMC.3)

➤ First class performance AMC module

Kontron's AdvancedMC processor module AM5010 provides outstanding performance in conjunction with comprehensive I/O and AMC interconnect capabilities designed according to the PICMG specifications AMC.0, AMC.1, AMC.2, AMC.3.

➤ Ultra Performance

The AM5010 is a highly integrated CPU board implemented as a double-width, mid-size Advanced Mezzanine Card (AMC) Module. The design is based on the Intel® Core™ 2 Duo LV 1.5 GHz processor with 4 MB L2 cache providing 667 MHz front side bus (FSB) speed combined with the Intel® 3100 server-class chipset.

➤ Ultra Capacity

The board includes up to 4 GB registered Double Data Rate (DDR2) memory with Error Checking and Correcting (ECC) running at 400 MHz. The AM5010 provides up to 8 GB Flash memory via a USB 2.0 NAND Flash Controller and offers further the capability for an onboard 2.5" SATA HDD.

➤ Ultra Connectivity

Supporting the PICMG sub-specifications AMC.1/.2/.3 the AM5010 ensures a comprehensive set of interconnecting capabilities. A x4 PCI Express lane (supporting 4 x1 PCI Express as well) according to AMC.1 guarantees high throughput for I/O intensive applications. The dual Gigabit Ethernet controller realizing the AMC.2 interconnect utilizes a x4 lane PCI Express interface to the 3100 chipset ensuring maximum packet performance. Two SATA ports compliant to AMC.3 allow flexible usage models of the AM5010 depending on the application requirements. Furthermore the integration of a graphic controller with an DVI-I interface to the front, combined with 2x USB, 2x GbE and a serial port via RJ45 provides a rich set of front I/O capabilities enabling the AM5010 for new application implementations beside the communication segment.

➤ Reliability

The careful design and selection of high temperature resistant components together with the elaborated heat sink construction ensures a high product availability. This, along with a high level of scalability, reliability, and stability, makes this state-of-the-art product a perfect core technology for long-life embedded applications.

➤ AMC systems

With the OM6062 AMC system Kontron offers the corresponding system solution for the AM5010. The OM6062 is a fully featured compact AMC system for up to 6 double-width AMCs (full-size or mid-size). It applies to entry level designs and compact system designs including an MCH for managed GbE and PCIe/SRIO switching. In combination with the AM5010 it is the ideal solution for multi-processor systems in medical, research and industrial automation applications as well as communication systems for 3G/Wimax, government, avionics and defense implementations.

AM5010: Intel Core2 Duo based Double PrAMC

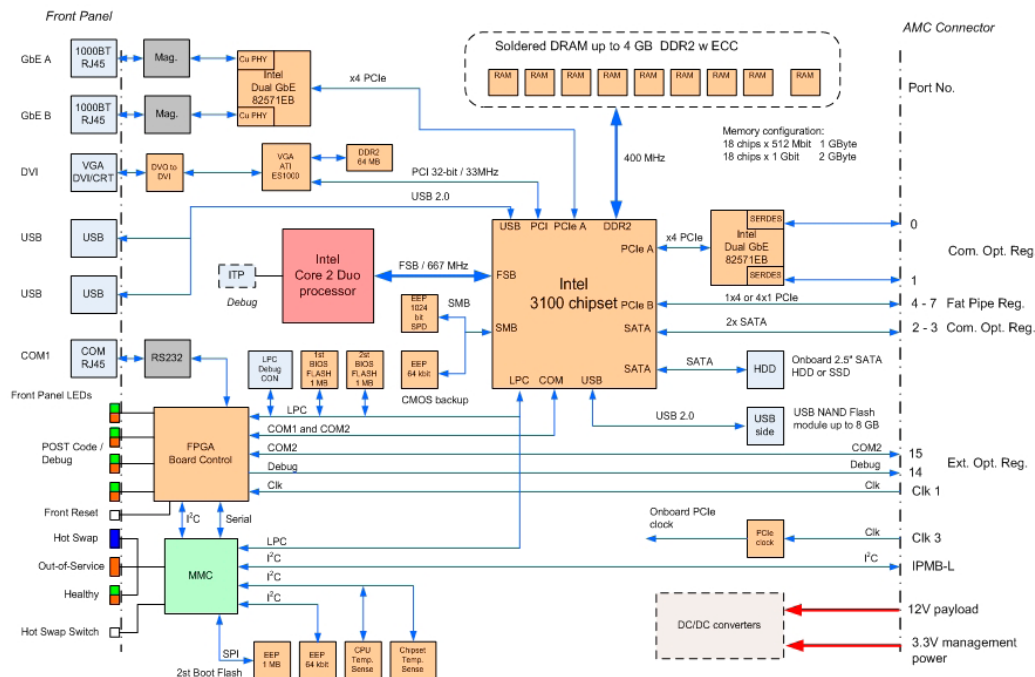

➤ Specification

System Processor	
	Intel® Core™2 Duo L7400 (LV), 1.5 GHz, 667 MHz FSB, 4 MB L2 cache 479-pin µFCBGA package, 2x 32KB L1 cache and 4 MB L2 cache The processor is passive cooled with a fanless heatsink. Forced air cooling at a specific flow rate is required.
Memory	
System memory:	Up to 4 GByte (soldered) registered DDR2 400 MHz with ECC
NAND Flash:	Up to 8 GByte NAND Flash via onboard USB 2.0 Flash controller
Flash (BIOS):	Two redundant 1 MB Firmware hubs (FWH)
EPROM:	Serial EEPROM (24LC64) 64 kbit
Onboard Controller	
Intel® 3100 chipset with integrated Memory and I/O Controller Hub:	Three x4 PCI Express ports, DDR2 SDRAM memory controller with ECC, six SATA 150 ports, four USB 2.0 ports, two UARTs, RTC, Interrupt Controller, Timer
Gigabit Ethernet:	Two Intel® 82571EB dual Gigabit Ethernet PCI Express bus controller
Graphic:	ATI ES1000 graphic controller with PCI 32-bit / 33MHz interface, maximum resolution of 1600x1200 pixels, external 64 MB DDR2 memory
Watchdog:	FPGA based, software configurable, two-stage Watchdog with programmable timeout ranging from 125 msec to 256 sec in 12 steps.
MMC:	Microcontroller with on-chip 512 kB Flash and 40 kB RAM, ext. 1 MB SPI Flash, 64 kbit EEPROM
RTC:	Integrated in 3100 and CMOS RAM with backup, battery replaceable.
AMC System Interconnect	
PCI Express:	1 x4 or 4 x1 PCI Express interface AMC fat pipes region port 4-7
Gigabit Ethernet:	2x 1000BASE-BX (SerDes) on AMC ports 0-1 (Common Options Region)
Serial ATA:	2x Serial ATA 150 ports on AMC ports 2-3 (Common Options Region)
Serial Interface:	1x Serial Port (COM2) on AMC port 15 (Extended Options Region)
Debug Interface:	1x Debug Port on AMC port 14 (Extended Options Region)
Front Panel Interfaces	
Gigabit Ethernet:	2x 1000BASE-TX on RJ45 connector
Serial Port:	1x RS232 UART interface on RJ45 connector
USB interface:	2x USB 2.0 port on 4-pin standard USB connector
DVI-I:	1x 29-pin VGA DVI I connector for analog or digital monitor
LEDs:	Four control and status bi color (red/green) LEDs
MMC Module Management Controller	
	Microcontroller with 40 kB RAM and redundant 512 kB Firmware Flash with automatic roll-back strategy. The MMC carries out IPMI commands such as monitoring several onboard temperature conditions, board voltages and the power supply status, and managing hot swap operations. The MMC is accessible via a local IPMB (IPMB-L) and two host Keyboard Style Interfaces (KCS).
Compliance	
ATCA:	PICMG 3.0 AdvancedTCA Base Specification R2.0
MicroTCA:	PICMG MTCA.0 Micro Telecommunications Comp. Architecture R1.0
AMC:	PICMG AMC.0: Advanced Mezzanine Card Specification R2.0 PICMG AMC.1: PCI Express and Advanced Switching R1.0 PICMG AMC.2: Gigabit Ethernet R1.0 PICMG AMC.3: Storage Interfaces R1.0
IPMI:	IPMI Intelligent Platform Management Interface Spec. V2.0 IPMI - Platform Management FRU Information Definition V1.0
PCI Express:	PCI Express Base Specification Revision 1.0a
Serial ATA:	Serial ATA 2.5 Specification
CE:	EN55022, EN55024, EN61000-6-2/-6-3, EN300386, EN60950-1
Vibration/Shock:	IEC60068-2-6 / IEC60068-2-27
Climatic Humidity:	IEC60068-2-78
WEEE:	Directive 2002/96/EC
RoHS:	Directive 2002/95/EC
Power Consumption	
With Core 2 Duo, 1.5 GHz, 2 GB:	max. 37 W
General	
Dimensions:	181.5 mm x 148,8 mm x 18.96 mm (mid-size/double-width)
MTBF:	tbd acc. Bellcore Issue 6, Ground Benign, Controlled, 30 C
Software Support	
	AMI BIOS, BIOS parameters saved in EEPROM, Boot order defined via MMC Serial over Lan, Support for Linux CGL
Environmental	
Operating temp.:	-5°C to +55°C (depending on system environment)
Storage temp.:	-40°C to +70°C
Humidity:	Operational: 5%-90% (non-condensing) Non-Operating: 5%-95% (non-condensing)

► Ordering Information

Article	Description
	Processor AMC
AM5010M-1.5GHz-2M	PrAMC, Intel Core 2 Duo (LV), 1.5 GHz, 667 MHz FSB, 2 GB memory
	Software
KIT-AM5010	User's Manual, Tool-Kit
LIN-BSP-AM5010	Linux Board Support Package
	Accessories
FLASH-UDOC-2GB	uDOC-Modul, low Profile, 2 GByte
FLASH-UDOC-4GB	uDOC-Modul, low Profile, 4 GByte
CP-HDD-2.5-SATA-xxx	various 2.5" SATA HDDs

► AM5010 Platforms



► Corporate Offices

Europe, Middle East & Africa

Kontron AG
 Oskar-von-Miller-Str. 1
 85386 Eching/Munich
 Germany
 Tel.: +49 (0)8165/ 77 777
 Fax: +49 (0)8165/ 77 219
 sales@kontron.com

North America

Kontron America Corporate Office
 14118 Stowe Drive
 Poway, CA 92064-7147
 USA
 Tel.: +1 888 294 4558
 Fax: +1 858 677 0898
 sales@us.kontron.com

Asia Pacific

Kontron Asia Inc.
 4F, No. 415, Ti-Ding Blvd.
 Sec.2, NeiHu District
 Taipei Taiwan 114
 Tel.: +886-2-2799-2789
 Fax: +886-2-2799-7399
 sales@kontron.com.tw

Kontron Modular Computers GmbH

Sudetenstr. 7
 87600 Kaufbeuren
 Germany
 Tel.: +49 (0)8341/ 803-0
 Fax: +49 (0)8341/ 803-499
 sales@kontron.com